

AEROFOIL AXIAL FLOW FANS

Ⓐ FIRE SAFETY

AIR MOVEMENT

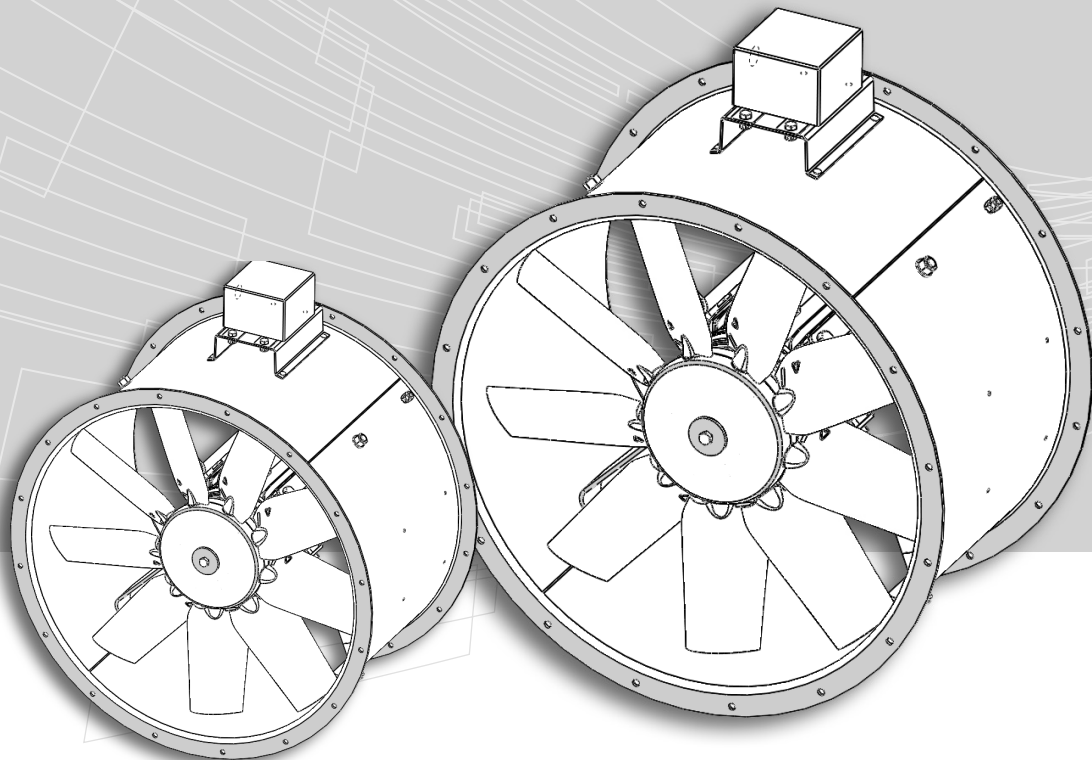

>> SAFETY, INSTALLATION AND MAINTENANCE INSTRUCTIONS
PART NO. 416421

| CONTENTS | PARAGRAPH |
|---|------------------|
| SAFETY | 1 |
| INTRODUCTION & PURPOSE - GENERAL | 2 |
| STORAGE & HANDLING | 3 |
| MECHANICAL INSTALLATION | 4 |
| ELECTRICAL INSTALLATION & OPERATION | 5 |
| - CAPACITORS | 5.1 |
| - OVERHEAT PROTECTION | 5.2 |
| - BEARING TEMPERATURE, VIBRATION & LEVEL MONITORING SENSORS | 5.3 |
| - ANTI-CONDENSATION HEATER | 5.4 |
| - EMERGENCY-USE FANS | 5.5 |
| - FANS WITH HAZARDOUS AREA MOTORS | 5.6 |
| - SWITCH-ON | 5.7 |
| MAINTENANCE | 6 |
| - FIXINGS | 6.1 |
| - LUBRICATION | 6.2 |
| - INFREQUENT USE | 6.3 |
| OVERHAUL / EXTENDED MAINTENANCE | 7 |
| FAULT FINDING | 8 |
| - ELECTRICAL | 8.1 |
| - MECHANICAL | 8.2 |
| DISPOSAL | 9 |
| EUROPEAN MACHINERY DIRECTIVE 2006/42/EC | 10 |

TABLE

| | |
|--------------------------------|---|
| ROUTINE MAINTENANCE PROCEDURES | 1 |
|--------------------------------|---|

FIGURES

| | |
|---|----|
| TWO STAGE CONTRA-ROTATING INSTALLATION | 1 |
| FIXING ARRANGEMENT OF TERMINAL BLOCK (DRAWING NO: D258302 F) | 2 |
| WIRING DETAIL - SINGLE PHASE FANS WITH DUCT MOUNTED TERMINAL BOX | 3 |
| WIRING DETAIL - SINGLE PHASE FANS USING TERMINAL BOX ON MOTOR | 4 |
| WIRING DETAIL - SINGLE-PHASE DIRECT-DRIVE MOTOR WITH SPEED CONTROLLER | 5 |
| WIRING DETAIL - SINGLE PHASE WEG MOTORS | 6 |
| WIRING DETAIL - THREE PHASE FANS WITH DUCT MOUNTED TERMINAL BOX | 7 |
| WIRING DETAIL - THREE PHASE FANS USING TERMINAL BOX ON MOTOR | 8 |
| WIRING DETAIL - THREE-PHASE MOTOR WITH ISOLATOR FITTED | 9 |
| WIRING DETAIL - THREE-PHASE DIRECT-DRIVE MOTOR WITH TRANSFORMER TYPE SPEED CONTROLLER | 10 |
| WIRING DETAIL - THREE-PHASE DIRECT-DRIVE MOTOR WITH ELECTRONIC TYPE SPEED CONTROLLER | 11 |
| WIRING DETAIL (THREE-PHASE DIRECT-DRIVE MOTOR WITH CHANGE OVER SWITCH) | 12 |
| DRAWING OF TORQUE SETTINGS FOR FIXINGS (DRAWING NO: D248284 K) | 13 |

AEROFOIL AXIAL - FLOW FANS

1. SAFETY



ATTENTION!

Only approved, qualified personnel familiar with the assessment of hazards and risks associated with fans, and with the use of tools and test equipment required to service such fans, should install, operate and maintain the product.



ATTENTION!

If the installer or user is unable to understand the information in this manual, or has any doubt that a safe and reliable installation, operation and maintenance of the equipment can be assured, Fläkt Woods limited or their representative should be contacted for advice.



ATTENTION!

Warnings and safety information relevant to specific operations are contained at the start of the sections to which they apply.



ATTENTION!

When fans are retained in storage, access by unauthorised persons must be prevented with the use of guards, barriers or secure premises such that fan impellers which may be rotating do not present a hazard.

2. INTRODUCTION & PURPOSE - GENERAL

The Aerofoil Axial-Flow Fan is a highly efficient air movement product, designed to operate between a temperature range of -40° to +50°C (-20°C on starting). When operating at low temperatures, ice formation on the fan assembly must be prevented. Some fans have a specification which calls for operation in high temperature emergency conditions, this will be identified on a special label on the fan casing (see also Paragraph 5.5).

The fan assembly is manufactured and specifically to fulfil the requirement of the installation for which it was designed. No deviation from the original requirement should be implemented without referring to Fläkt Woods Limited head office in Colchester. Any queries regarding safety or operating problems should be referred to the local Fläkt Woods office, sales centre or representative, together with full fan/motor nameplate details. Should a fan failure occur whilst the product is under warranty, the Fläkt Woods service centre in Colchester should be contacted before any repair work is undertaken.

If speed control is to be provided by means of a frequency inverter, then please seek drive selection and compatibility advice from Fläkt Woods.

3. STORAGE & HANDLING



ATTENTION!

When fan assemblies are retained in storage then please ensure that access by unauthorised persons must be prevented with the use of guards, barriers or secure premises such that fan impellers that may be rotating (windmilling) do not present a hazard.

If the fan assembly is to be stored; check immediately on receipt that it is as ordered and that it has not been damaged in transit. Where the fan is delivered in a crate (or similar) the crate should be considered as a protective device only. The crate must not have equipment stacked on it and it must not be stacked on other equipment. The crate structure must not be used as a lifting aid, unless otherwise indicated.

A fork-lift truck or similar should be used for moving the crate. The fan should be stored in a safe, clean, dry, vibration free, location. If such storage conditions are not available the motor anti-condensation heater (if fitted) should be connected to an appropriate electrical power supply to prevent motor condensation forming and the fan should be stored in an appropriate container. A regular monthly rapid spin of the impeller is recommended to prevent grease hardening and possible brinelling of the bearings; the impeller should not be in the same angular position after rotation.

When dismantling the crate to gain access to the fan assembly care should be taken to avoid injury from sharp edges, nails, staples, splinters, etc.

If the fan is to be stored for 12 months or more, an inspection by Fläkt Woods Limited service centre in Colchester before commissioning is advised.

4. MECHANICAL INSTALLATION



ATTENTION!

It is recommended that suitable safety guards form part of the Installation. Such devices, and advice on safety devices, are available from Fläkt woods limited.



ATTENTION!

Where the fan is delivered in a crate (or similar), the crate must be considered as a protective device only, and must not be used as a lifting aid unless otherwise indicated.



ATTENTION!

All lifting aids used during installation should be adequately certified to carry the weight of the equipment being lifted.



ATTENTION!

Always wear appropriate protective clothing (including hard hats, eye protectors and ear defenders) when working in the vicinity of the fan assembly.



ATTENTION!

During lifting of the fan all personnel must be clear of the area below the suspended fan.



NOTE!

Before installing the fan assembly, check that it has not been damaged in transit, that there is no deformation of the fan casing, that the impeller rotates freely and that the fan and motor nameplate data complies with the requirement of its use. If the fan assembly has been stored, the resistance of the motor windings to earth should be measured (at 500V d.c). If any reading is less than ten megohms the motor should be dried and re-checked before it is switched on.

Fan assemblies can be heavy (up to 8 tonnes, depending on fan and motor size, with ancillary equipment such as silencers, guards, bellmouths, adding to the weight), are sometimes unwieldy, and should be lifted slowly to prevent damage and distortion. Proper precautions must be taken, and certified lifting aids used, to ensure the fan is well supported and stable before lifting into position.

Flange holes or mounting feet holes can be used for lifting but more than one hole must be used to spread the load. If special lifting points are provided they must be used. The fan must be installed such that it is correctly positioned in accordance with the required airflow direction. An airflow indication arrow is shown on the fan nameplate. For two-stage, contra-rotating fans see Figure 1. Sharp bends in the ductwork close to the fan must be avoided. Adequate room must be allowed round the fan for inspection and maintenance.

The component parts of the fan assembly, including (if fitted) anti-vibration mounts, silencers, bellmouths, flexible connectors (and their clips), purlin boxes, weather proofing, platforms, supports, chains and harnesses, etc. must be fully aligned before being bolted together so that no distortion or stress is placed on the equipment.

Appropriate fixings, with the correct torque applied, must be used to secure the fan into position. If in doubt about the torque of a particular fixing, contact Fläkt Woods Limited for advice. The final position of the fan must be strong and rigid enough to take the weight and operating forces of the fan and any other weight applied during installation. Vibration isolators, appropriate for the weight and thrust of the fan, are recommended in order that any fan vibration is isolated to minimise transmission to surrounding fixtures.

If vibration isolators are used, flexible connectors and flexible electrical conduit should also be used. The vibration isolators and flexible connectors must not be used to align fixing points that are clearly misaligned. If any component parts do not easily fit together the cause must be investigated and rectified.

Motors are fitted with a drain hole in each end cover, and in the terminal box. The motor drain hole should be at the lowest point of the motor when it is installed. Plugs that cover the drain holes should either be removed entirely if condensation is liable to occur due to large variations in operating temperature, or removed periodically to allow any general build-up of condensation to drain away. The frequency of plug removal will be dictated by environmental conditions, a record should thus be kept.

Bifurcated fans when mounted on their horizontal axis should have the 'tunnel opening' facing downwards between 3 o'clock and 9 o'clock positions, to minimise the risk of water ingress.

After installation all packing materials must be disposed of in accordance with Paragraph 9.

5. ELECTRICAL INSTALLATION & OPERATION



ATTENTION!

No work should be attempted before completely isolating the fan assembly, its anti-condensation heater (if fitted), and its controls from all electrical supplies, and allowing the rotating parts of the fan to come to rest.



ATTENTION!

Before entering the area ensure that all fumes, dust, toxic emission, heat etc. have dispersed from the local environment, and the fan blades are not likely to windmill.



ATTENTION!

The fan assembly contains rotating parts and electrical connections which can be a danger and cause injury. If there is any doubt that a safe and reliable installation of the fan can be assured; Fläkt Woods limited or their representative should be contacted for advice.



ATTENTION!

If the fan assembly is designed for high-temperature emergency-use; it is imperative that the wiring used is rated for the appropriate high temperature category, and that all switches and controls are overridden during the emergency operation.



ATTENTION!

If the fan stops due to an overheat situation, the overheat protection thermostat may reset as the temperature cools and automatically restart the fan if power is still applied.



ATTENTION!

Always wear appropriate protective clothing (including hard hats, eye protectors and ear defenders) when working in the vicinity of the fan assembly.

The fan assembly is fitted with either a terminal box on the motor or a terminal box on the fan duct. The electrical supply to the fan assembly should be connected to the terminal box by an appropriately qualified electrician. It is good practice to fit a clearly marked isolator switch close to the fan, and have a clearly marked and accessible additional switch remote from the fan. The two switches allow safe control of the fan and provide a means of safely isolating the fan during maintenance. A suitable earth must also be connected. Sufficient cable length should be provided to allow for the flexibility of the fan on its mountings.

A connection diagram providing **wiring** details is supplied with all fan assemblies (typically inside the terminal box lid). Figures 3 to 12 show details of the wiring to the terminals of smaller fans. Figure 2 shows the correct assembly sequence of terminal box parts, and the torque to be applied. It is essential that no lockwashers or nuts are placed between the motor lead eyelet, connecting link or customers supply lead eyelet (when fitted).

Fuses in the fan electrical control circuit must be sufficiently rated to carry the starting current as indicated on the motor nameplate, but they should be regarded as only protecting the wiring against the effects of short circuits or earth faults. The fuses are not suitable for overload protection. To provide full protection for the motor, a starter panel with overload protection should be used, and an isolator switch must be incorporated into the circuitry. The isolator switch should be a lockable type that will allow the operator/maintainer to isolate the fan from the electrical supply before working on the assembly.

If a **speed controller**, or other controlling equipment, forms part of the system it should be able to control the fan within safe limits. Sufficient fan speed must be maintained to open any shutters that may be in the air-flow. The controlling equipment should be securely located, and should not be, or cause, a radiation hazard.

For single phase supplies, three-wire control is preferable to two-wire control. Two-wire control can be used on motors up to a full load current of 3 amps, but above 3 amps three-wire control is recommended to avoid increased temperature rises in the motor windings. Care should be taken to ensure that the fan is able to be controlled by a speed controller. Fläkt Woods Limited can be contacted for advice on all forms of speed controllers and other control equipment supplied by the Company. Speed controllers should not be used without prior agreement with Fläkt Woods Limited.

Fans with a duct-mounted terminal box must have their electrical supply fed through an entry point in the side of the box. Unused entry points must be sealed with weatherproofed plugs or grommets. Fans with a motor-mounted terminal box also have the electrical supply fed through an entry point in the side of the box. The cable must be threaded through a gland assembly, and the gland assembly should be tightened sufficiently to hold the cable and provide a weatherproof seal.

5.1 CAPACITORS (SINGLE PHASE MOTORS ONLY)

Physically small sized capacitors are mounted on the motor during manufacture. Larger capacitors, are supplied separately and must be fitted externally from the motor. Capacitors for hazardous area motors must be located outside the hazardous area.



ATTENTION!

Be aware that electrical components can operate at high temperatures. Keep Flammable Materials away from these and their connections. Whilst it is extremely rare, the possibility of component malfunction should be taken into consideration.

5.2 OVERHEAT PROTECTION

Motor overheat protection (if fitted) can be enabled on all single-phase and three-phase motors. Overheat protection is achieved by the use of either thermostats or thermistors. The protection devices are wired in either of the following two ways:

- on single-phase and three-phase motors with a full load current of up to and including 6.3A: thermostats can be wired in series. If the unexpected re-closure of the self-resetting thermal cut-out can cause a hazard, or is prohibited by regulation, it must be connected into a control circuit that will not allow the fan to restart until the circuit is manually reset.
- on single-phase and three-phase motors with a full load current above 6.3A: thermostats are wired to separate terminals (K – K) within the terminal box; they operate by opening and closing with temperature and must be wired to directly control the motor start contactor. Thermistors are wired to separate terminals (S –S) within the terminal box; they operate by changing their resistive value with temperature and must be wired to control the motor start contactor via a suitable relay.



NOTE!

When the fan is intended to be used for emergency high temperature operation, overheat protection must be by passed in the event of an emergency (see Section 5.5).



NOTE!

When the motor cools the thermostat will reset; the motor however must not be able to start until the motor start contactor is manually reset.

5.3 BEARING TEMPERATURE AND VIBRATION MONITORING SENSORS

Monitoring sensors (if fitted) in the fan system should be wired to automatically switch off the fan if a fault occurs, or provide an indication of a fault. If the fan is automatically switched-off by a monitoring sensor the wiring must ensure that it is fully isolated and will not automatically reset. If the fan is designed for emergency use the circuit must be wired to allow the emergency use system to override all monitoring devices and immediately switch on the fan in the case of such an emergency situation (see Section 5.5).

5.4 ANTI-CONDENSATION HEATER

Anti-condensation heaters are terminated in a terminal box on the fan and must be externally wired to automatically receive the appropriate supply when the motor is switched to off. When the motor is switched on the anti-condensation heater is not required and thus must be automatically switched out of circuit.

5.5 EMERGENCY-USE FANS

Where the fan assembly is designed for emergency-use smoke-extraction at high temperature, the temperature/time capability will be shown on a special label adjacent to the main nameplate. An automatic control system, or a clearly marked remotely sited emergency-use switch, must be fitted to override all other switches and controls and immediately switch on the fan in the case of such an emergency situation.

Appropriately rated high temperature cable must be used between the remote switch and the fan, and the electrical supply must be from a guaranteed or separately maintained source to enable the unit to continue running during the emergency condition. After such an emergency the fan must be removed, refurbished or safely disposed of (see Paragraph 9), and replaced as necessary.

5.6 FANS WITH ATEX OR HAZARDOUS AREA MOTORS

Fans with ATEX/hazardous area motors are designed for use in locations where there are liable to be fumes, dust or flammable/explosive gases. Installation should be carried out by qualified personnel. Special care must be exercised when connecting such units to ensure that a secure ATEX/hazardous area connection is achieved.

Great care must be taken to ensure that the thread of cable glands, or conduit, matches its corresponding thread so that the entire installation achieves the level of protection required. Long cased, fully ducted fans fitted with ENV89 motors are not fitted with an external terminal box. The supply cable to the motor terminal box must be fed through the conduit hole in the fan duct and connected into the terminal box before the fan is fully installed (i.e. before the inlet and outlet ducts are fitted).

Any electrical control gear (including the capacitor in the case of single-phase motors) must be located outside the hazardous area if it is not certified for use in that zone. The motor should not be allowed to become coated with dirt/dust, etc. which could restrict surface cooling and consequently raise the temperature of the motor carcass.

5.7 SWITCH ON

Before switching on, confirm that the electrical supply is fully compliant with the requirement of the motor as detailed on the motor nameplate, that the fan is correctly installed, all component parts and fixings are secure, safety guards are in place and no loose articles are present in the vicinity.

Immediately after switch-on check for the correct direction of rotation. If the rotation is incorrect interchange any two phases of the incoming supply at the motor terminal block, to rectify this for three phase motors.

For single-phase motors, the motor winding leads should be interchanged at the motor terminal block. In the case of BT and CT motors, these are identified by black and red coloured wires. In the case of other motors these wires are labelled "U1" and "U2".

Check the assembly for smooth, low-vibration running, and check that the current consumption is within the full load current specified on the nameplate. The fan must not be switched on and off in a manner that could cause overheating of the motor or its wiring.

6. MAINTENANCE



ATTENTION!

No maintenance work should be attempted before switching off and completely isolating the fan assembly, its anti-condensation heater (if fitted), and its controls, from all electrical supplies and allowing the rotating parts of the fan to come to rest.



ATTENTION!

Before entering the area ensure that all fumes, dust, toxic emission, heat etc. have dispersed from the local environment, and the fan blades are not likely to windmill.



ATTENTION!

All lifting aids used during maintenance, and all lifting points utilised, should be adequately certified to carry the weight of the equipment being lifted. (See paragraph 4).



ATTENTION!

Always wear appropriate protective clothing (including hard hats, eye protectors and ear defenders) when working in the vicinity of the fan assembly.

Maintenance must be carried out on the fan assembly by appropriately qualified personnel using the correct tools and equipment. A regular routine maintenance schedule should be established, and a record kept. A list of suggested intervals are given in Table 1.

Where the environment is particularly dirty, a reduction in the intervals may be necessary. Internal and external fan surfaces may be cleaned with low pressure clean water and non-abrasive additives. Direct application of water from any direction to the motor drain plugs must be avoided.

After maintenance ensure that no loose articles are present in the vicinity of the fan, that all safety guards, chains or steel ropes, etc., are properly secured into their original location, and that any temporary device used to stop the fan blades windmilling has been removed.

6.1 FIXINGS

It is essential to ensure that all fixings on the fan assembly are secure. When examining and checking the security of fixings during routine maintenance (see Table 1 Items 10 and 11), those fixings that have locking devices fitted or are painted over, need not be disturbed if they can be seen to be secure. Any locking devices that are disturbed during maintenance must be discarded and replaced with new identical devices.

Thread forming screws must have locking compound applied when being reused. Those fixings that have no locking devices fitted and are not painted over, should be checked at 95% of their original setting to ensure no unnecessary disturbance of the fixing. See Figures 6 and 7 for torque setting details. If in doubt about the torque of a particular fixing contact Fläkt Woods Limited for advice.

6.2 LUBRICATION

In addition to routine maintenance motor bearings will in the longer term require attention. If the motor bearings are greased through extended lubricators, a quality of grease should be periodically applied in accordance with the information on the fan or motor nameplate and/or instructions provided. A compatible grease type must be used and it is essential that every trace of water and dirt is removed from around the grease points and that a clean grease gun is used. Only low pressure should be needed to inject the specified quantity of grease. If a high pressure is required, the cause should be investigated. Grease points are generally located in the region of the duct terminal box.

For motors that require re-lubrication, a separate instruction is issued with each fan/motor configuration. This details both the period between lubrication and the type of grease to be used. If you require any further details please contact Fläkt Woods Limited direct.

6.3 INFREQUENT USE

If the fan assembly is to be used less frequently than once a month, or for emergency-use only, the following additional maintenance procedures should be carried out, and a record kept:

- The resistance of the motor windings to earth, should be measured (at 500V d.c) each month. If the reading is less than ten megohms, the motor should be dried in a warm airflow (typically 40°C) and re-checked before running the motor.
- The fan should be operated between 15 and 30 minutes each month ensure that correct lubricant conditions are maintained within the bearings.
- The 'emergency-use' system should be run continuously for a minimum of fifteen minutes each month, the test should ensure that the emergency use control system overrides all other controls and switches (see Paragraph 5.5).
- If an anti-condensation heater is fitted, check each month that it is automatically switched on (drawing current) when the motor is switched to off.

7. OVERHAUL / EXTENDED MAINTENANCE

Advice on motor overhaul procedures, bearing/seal replacement, motor replacement, motor rewinding, spare parts, condition monitoring, vibration analysis, refurbishment, etc. is available from Fläkt Woods Limited service centre in Colchester.

For emergency use fans it is recommended that the motor shaft seals and bearings are replaced after 20,000 hours or 5 years of normal operation whichever ever comes sooner, and that the motor is rewound to its original specification after 40,000 hours of normal operation to ensure that adequate insulation life is available should the fan be required for emergency operation.



NOTE!

With High Temperature fans, only an authorised company may undertake the maintenance. Failure to do so may invalidate any warranty and CE Certification. The motor manufacturer's specification sheets are available through Fläkt Woods Limited.

After overhaul/extended maintenance the fan assembly must be correctly installed back into its original position in accordance Paragraphs 1, 2, 3 and 4 of this document.

For advice on "switching on" after maintenance, please refer to paragraph 5.7.

8. FAULT FINDING

Please refer to the safety warnings (“attention” items) stated within paragraph 6.



NOTE!

The routine maintenance procedures detailed in Paragraph 6, and Table 1, of this document are designed to help keep the fan operational and fault free.

8.1 ELECTRICAL

Check that the electrical connections to the unit are secure.

Check that the voltage applied at the fan terminals is as specified on the motor nameplate, and is balanced.

Measure the current on each phase (one phase in the case of single-phase motors) of the motor in turn and check that the current consumption is within the full load current specified on the motor nameplate.

Measure each motor winding to earth, and between each winding, using a 500V d.c insulation tester. If the reading is less than ten megohms the reason is likely to be dampness in the motor. To dry the motor place it in a warm (typically 40 degrees centigrade) dry airstream and regularly monitor the motor until the insulation reading is restored to ten megohms or greater. If the reading remains less than ten megohms a break-down in the motor winding insulation could be the reason, and a motor rewind/overhaul may be necessary.

Ensure that there is no smell of burnt insulation in the vicinity of the motor. If this is the case, please seek advice from Flakt Woods UK (Colchester Office)

8.2 MECHANICAL

Check that there are no obstructions to the motor shaft or impeller blades, that the blades are clean, and that there are no loose articles or debris in the vicinity.

Rotate the motor shaft by hand. Investigate any sound of grinding noises, internal chaffing, rubbing or stiffness. Any observed defect may indicate that the bearings require lubrication or replacement.

Ensure that all fixings are secure.

9. DISPOSAL

Metal components of the fan/motor should be segregated and separately recycled. The following items of material should be safely disposed of in accordance with local health and safety regulations:

- electrical lead coverings,
- motor winding insulation materials,
- bearing lubricant,
- motor/fan terminal block,
- paintwork,
- plastic parts,
- packing materials,
- silencer infill (Note that a face mask and gloves should be worn when handling the infill. If the infill is particularly dry or is damaged it should be damped-down before disposal).

10. EUROPEAN MACHINERY DIRECTIVE 2006/42/EC

1.7.4.2 CONTENTS OF THE INSTRUCTIONS

CLAUSE C)

Please see a typical example of an EC declaration of conformity certificate (below), which shows particulars of the machinery offered.

CLAUSES G) AND H)

Fans should not be operated above maximum speed indicated, or run where the fan is operating in a stalled condition. Fans should also not be run in reverse unless specific advice is sought from Fläkt Woods.

CLAUSES I) AND J)

Fans should be isolated from support structures by means of anti-vibration mounts and from adjacent ductwork by flexible connections.

CLAUSE K)

Care should be taken when installing fans to ensure that the product orientation is correct in relation to direction arrows which indicate direction of air movement and impeller rotation direction. Where two-stage fans are shipped as two separate fan units, please refer to the appropriate two-stage assembly drawing, which is available on request. Also see figure 1.



EC DECLARATION OF CONFORMITY

Herewith we declare that the air movement equipment designated below, on the basis of its design and construction, in the form brought on to the market by us, is in accordance with the relevant safety and health requirements of the EC Council Directives on Machinery, Electromagnetic Compatibility. If alterations are made to the machinery without prior consultations with us, this declaration becomes invalid. We further declare that the equipment identified below may be intended to be assembled with other equipment/machines to constitute machinery, which shall not be put into service until the assembled machinery has been declared in conformity with the provisions of these EC Council Directives.

Designation of equipment: **Direct Drive Axial Flow Fan**

Series/type:

Fläkt Woods Limited
Order/Stroke No:

Relevant EC Council Directives: Machinery Directive (2006/42/EC).
Electromagnetic Compatibility Directive (2004/108/EC) where applicable (3)

Applied harmonized standards ¹⁾ in particular: EN ISO 12100:2010, EN 60204-1:2006, EN ISO 12499:2008
EN ISO 5801:2008, EN ISO 13350:2008, EN 61000-6-2:2005, EN 61000-6-1:2007
EN 61000-6-3:2007/A1:2011/AC:2012, EN 61000-6-4:2007/A1:2011

Applied national standards ²⁾ in particular: BS 848-2-1:2004 (BS ISO 13347-1:2004)
BS 848-6:2003 (BS ISO 14695:2003)
BS 848-7:2003 (ISO 14694:2003)

Basis of self attestation: Quality Assurance to BS EN ISO 9001:2008
BSI Reg Firm Cert No. FM 155.

Technical File Compiled By: Iain Kinghorn
Axial Way, Colchester, CO4 5ZD, UK

Signature of Manufacturer:  Place: Colchester
Date: **04/02/2015**

Position of signatory: Ian Morehouse
Managing Director

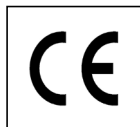

- Notes:
- 1) For the complete list of applied standards and technical specifications see Fläkt Woods documentation.
 - 2) Where no relevant harmonized standards exists.
 - 3) Woods fans are driven by AC induction motors which are inherently compliant if supplied with a truly sinusoidal AC supply. Where the fan motor is supplied via an inverter or other electronic control, verification of its compatibility together with cabling should be sought from the control supplier.

Fläkt Woods Limited
Axial Way
Colchester CO4 5ZD
United Kingdom
Tel: +44 (0) 1206 222555
Facsimile: +44 (0) 1206 222777
Email: info.uk@flaktwoods.com
Website: www.flaktwoods.com

Registered in London No. 233771
Registered office Axial Way, Colchester, CO4 5ZD, UK

© Fläkt Woods Limited December 2009

TABLE 1

| Routine Maintenance Schedule | Every 6 Months | Every 12 Months | Comments |
|---|-----------------------|------------------------|--|
| 1. Examine the airways in to the fan guards (if fitted) | * | | Remove and debris that may have accumulated round the guards |
| 2. Examine motor cooling fins | * | | Remove any material / dirt build-up between the motor fins |
| 3. Examine impeller for dirt build-up or any physical damage | * | | Remove any build-up of dirt. Ensure impeller is secure. Replace impeller if it is damaged |
| 4. Check condition and tautness of fan safety support chains / harnesses / ropes (if fitted) | * | | Clean safety supports. Replace them if there is any deterioration / corrosion |
| 5. Examine and operate vibration sensors (if fitted), and temperature sensors (if fitted) | * | | Check operation using built-in sensor test features or dummy signals. Check that the fan is automatically switched off, or a warning indication is provided, when the sensors / switches indicates a fault |
| 6. Examine condition of safety guards (if fitted) and their fixings | * | | Clean safety guards. Replace them if there are any signs of damage |
| 7. Check operation of anti-condensation heaters (if fitted) | * | | Switch off power to the motor. Check that the anti-condensation heater is energised (drawing current) |
| 8. On 'bifurcated' motors remove the impeller and inspect the packing located behind the motor shaft-seal retaining plate | * | | Replace the 130mm Duramid seal if it is damaged |
| 9. Examine the clearance between the fan impeller blade tips and the fan duct. Check the angle, and the security of the impeller blades | | * | Ensure that the gap between the impeller blade ends and the fan duct is even and adequate. If in doubt about the gap contact Flakt Woods for advice. Ensure that the impeller blade is secure. The blade angle must not be changed before contacting Flat Woods Ltd for advice |
| 10. Check torque of fan-to-support fixings | | * | It is essential to confirm that all fixings are properly fitted, are tight, and are fully driven home (see Paragraph 6.1) If in doubt about the torque of a fixing contact Fläkt Woods Ltd for advice |
| 11. Examine motor, fan and ancillary equipment fixings | | * | It is essential to confirm that all fixings are properly fitted, are tight, and are fully driven home (see Paragraph 6.1) If in doubt about the torque of a fixing contact Fläkt Woods Ltd for advice |
| 12. Check movement of vibration isolators (if fitted) | | * | Check freedom of movement. Tighten fixings if necessary |
| 13. Check motor voltage and current consumption | | * | Ensure voltage and full load current are as specified on the motor nameplate |
| 14. Inspect paintwork / galvanising | | * | Treat any areas of damage with suitable anti-corrosion paint |
| 15. Grease motor bearings | | * | Check requirement in accordance with paragraph 6.3 |
| 16. Check fan assembly wiring | | * | Check security and condition of all wiring (including the earth) |

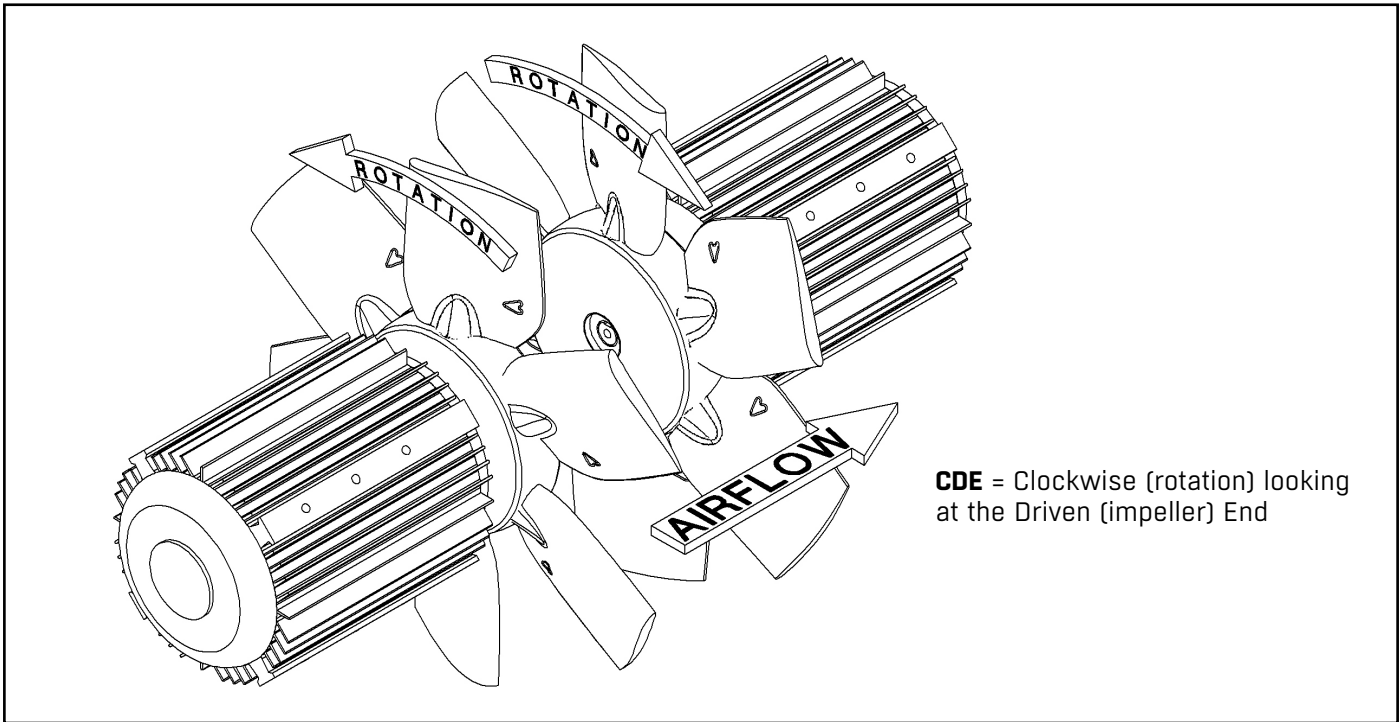

CDE = Clockwise (rotation) looking at the Driven (impeller) End

A STANDARD TWO STAGE CONTRA-ROTATING AXIAL FAN COMPRISES A FORM A, RIGHT HAND FAN FOLLOWED BY A FORM B, LEFT HAND FAN.

This does not apply to: identical fans in series, Bifurcated Fans or fans fitted with guide vanes.

IMPORTANT NOTE:

THIS DRAWING SHOWS THE CORRECT ASSEMBLY SEQUENCE OF TERMINAL PARTS.

IT IS ESSENTIAL THAT NO LOCKWASHERS OR NUTS ARE PLACED BETWEEN THE MOTOR LEAD EYELET, CONNECTING LINK OR CUSTOMERS SUPPLY LEAD EYELET (WHEN FITTED).

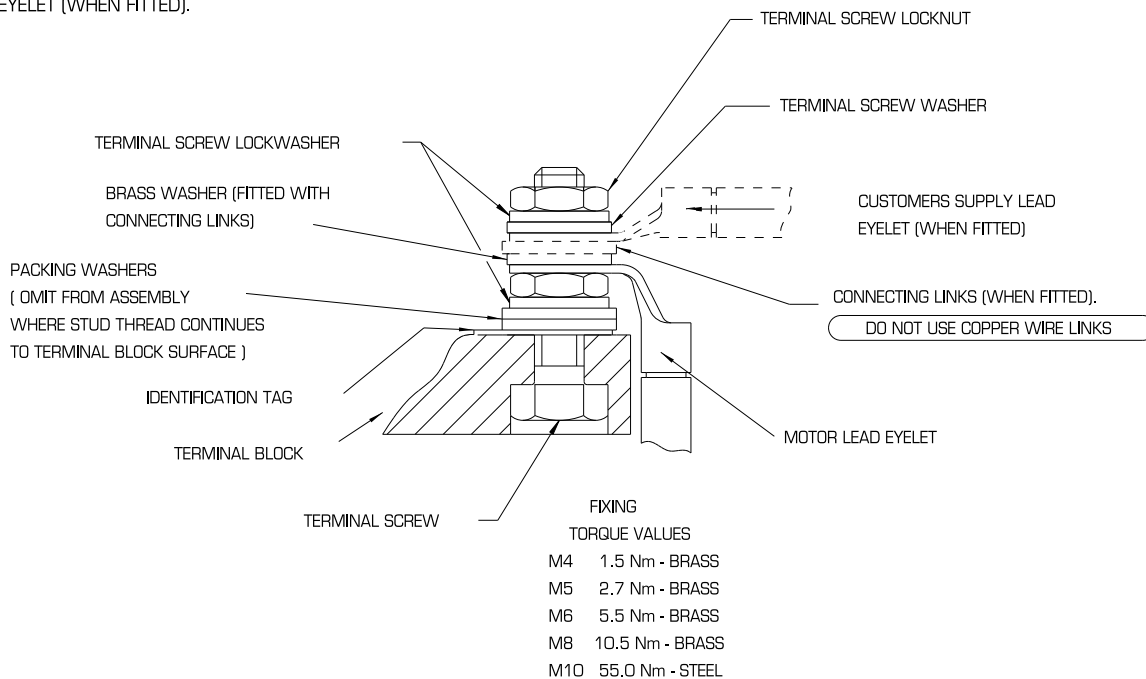

FIXING ARRANGEMENT OF TERMINAL BLOCK

Applies to only HT (high temperature smoke venting fans) and Bifurcated JM fans.
It does not apply to Series 33 Bifurcated JM fans

FIGURE 3

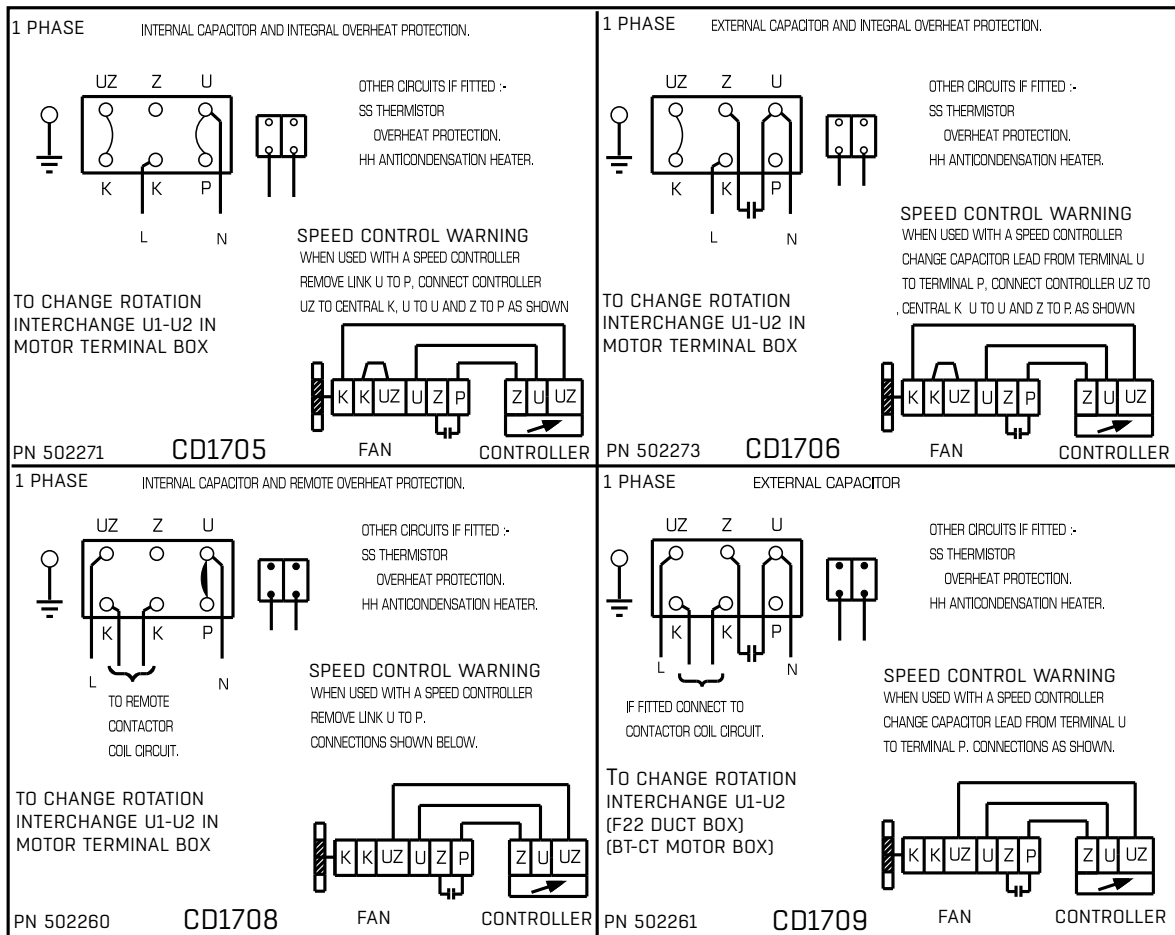

WIRING DETAIL: SINGLE PHASE FANS WITH DUCT MOUNTED TERMINAL BOX

Wiring leads in BT/CT motors are black and red in colour instead of being marked as "U1" and "U2".

FIGURE 4

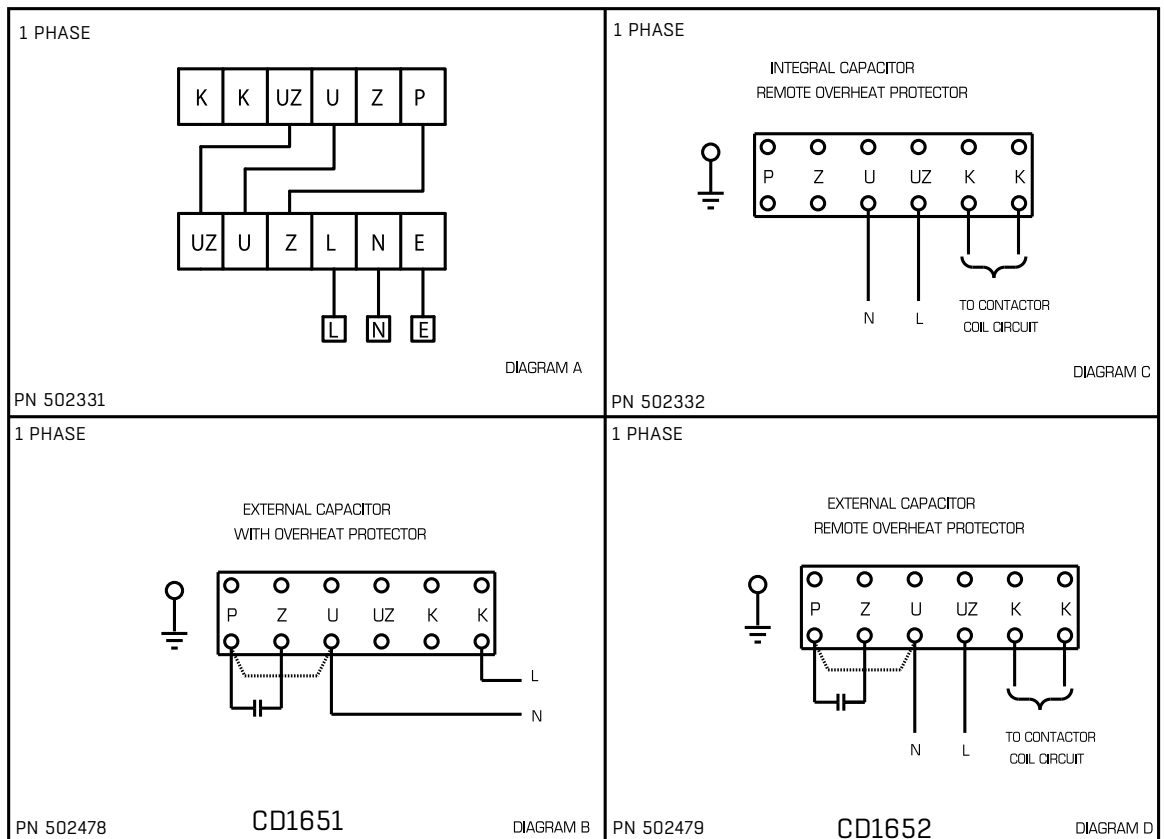

WIRING DETAIL: SINGLE PHASE FANS USING TERMINAL BOX ON MOTOR

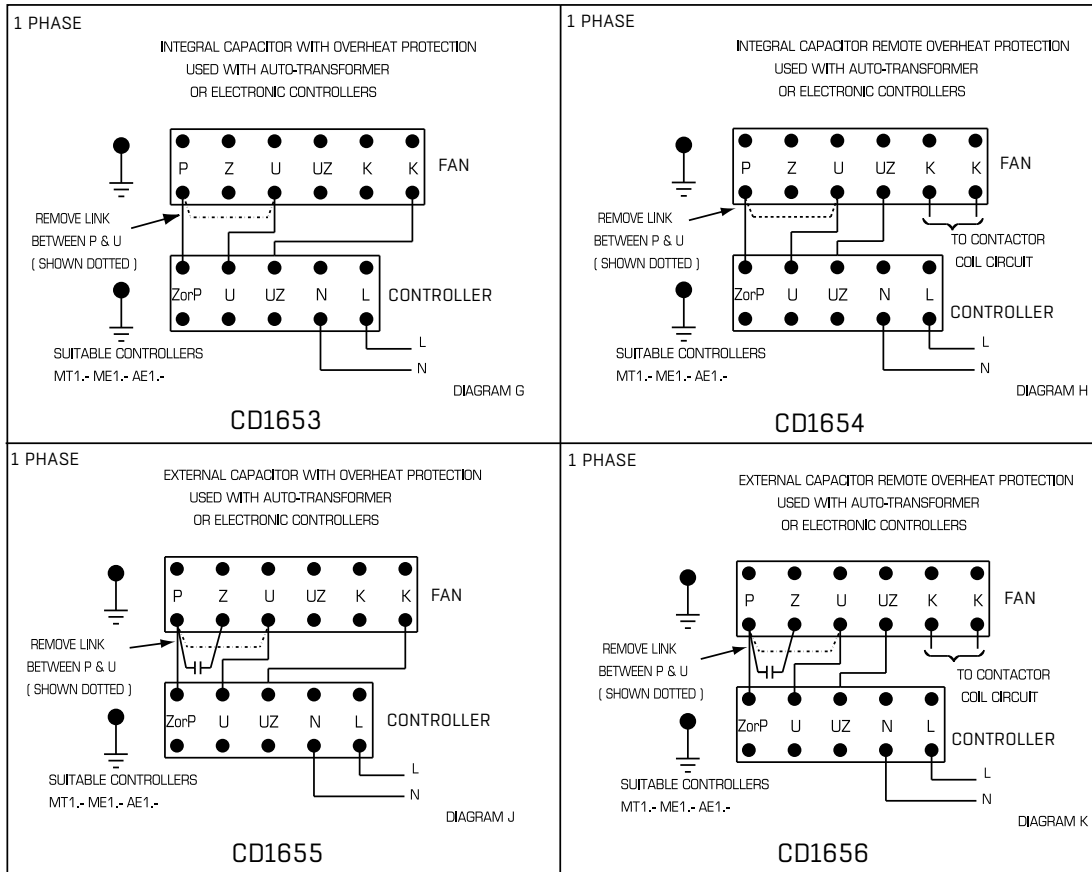

WIRING DETAIL: SINGLE-PHASE DIRECT-DRIVE MOTOR WITH SPEED CONTROLLER

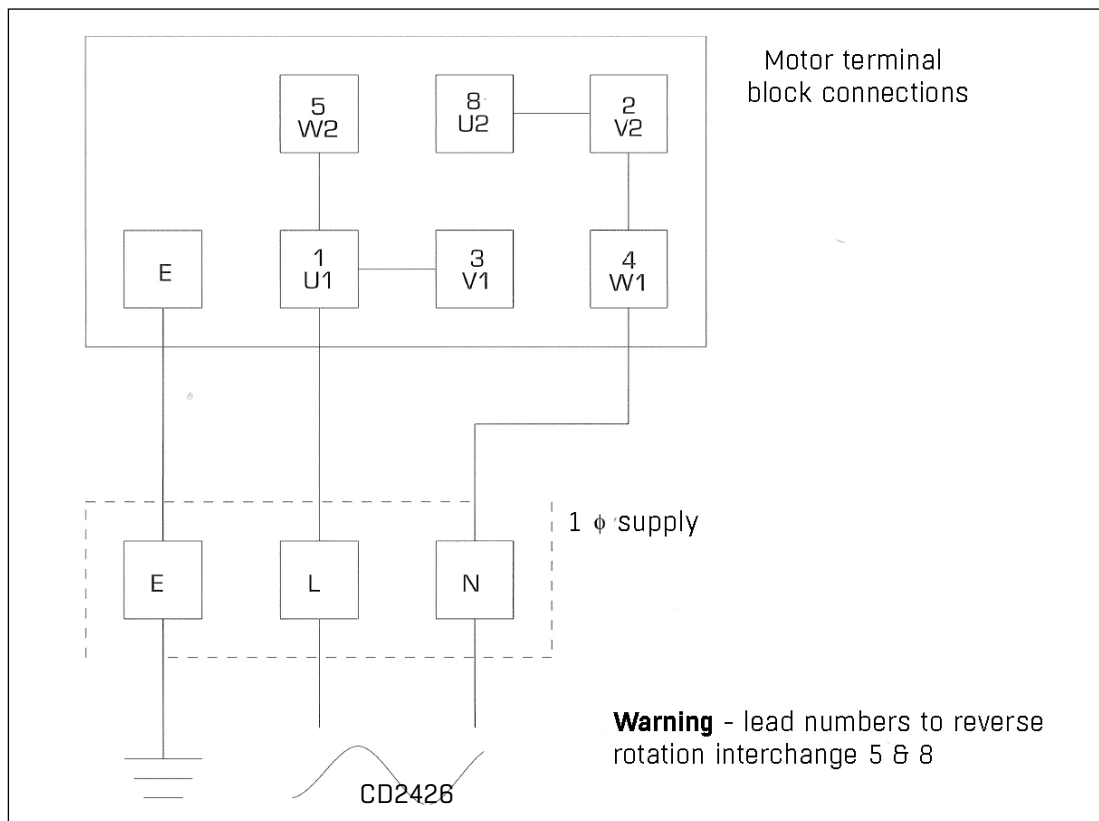

WIRING DETAIL: SINGLE PHASE WEG MOTORS

FIGURE 7

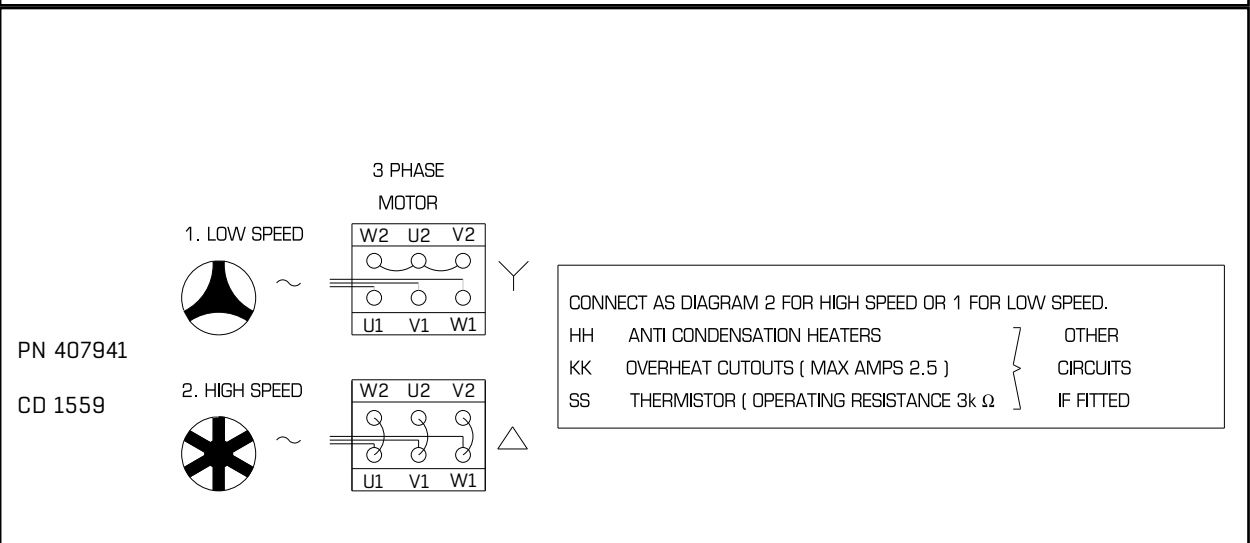
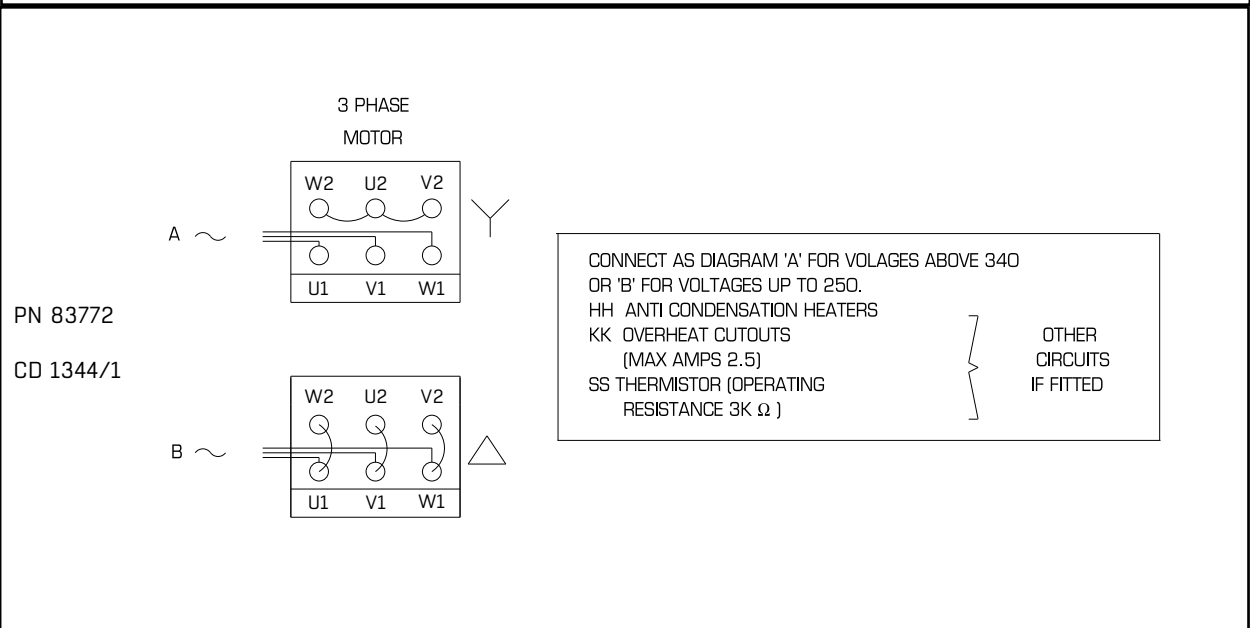
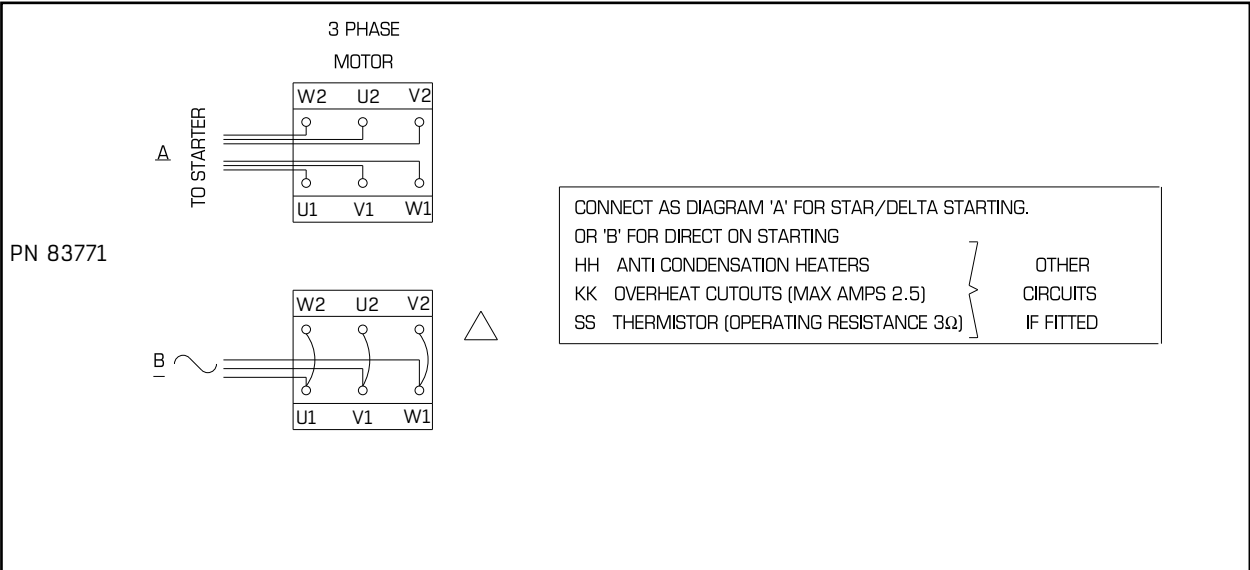

WIRING DETAIL: THREE PHASE FANS WITH DUCT MOUNTED TERMINAL BOX

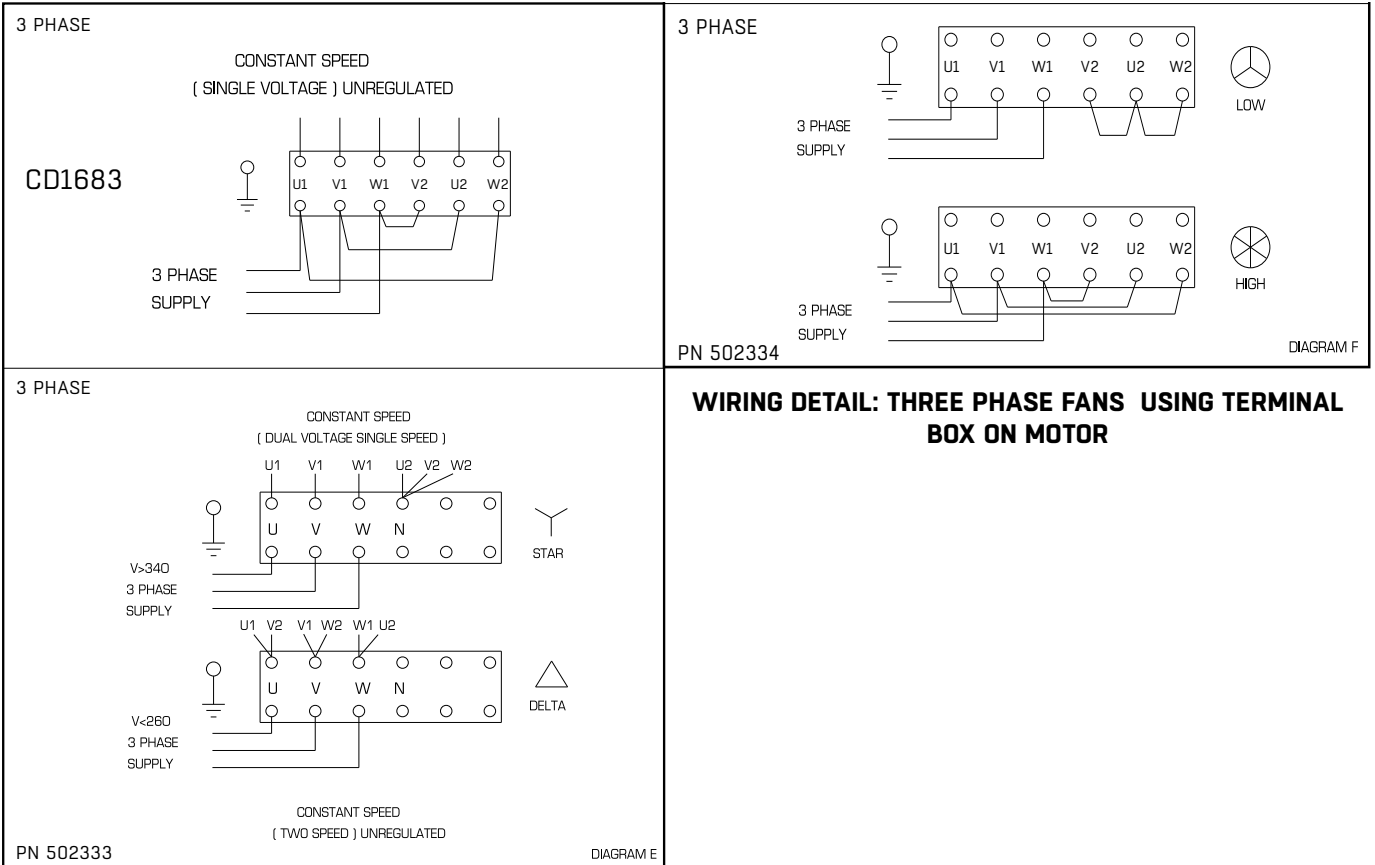

WIRING DETAIL: THREE PHASE FANS USING TERMINAL BOX ON MOTOR

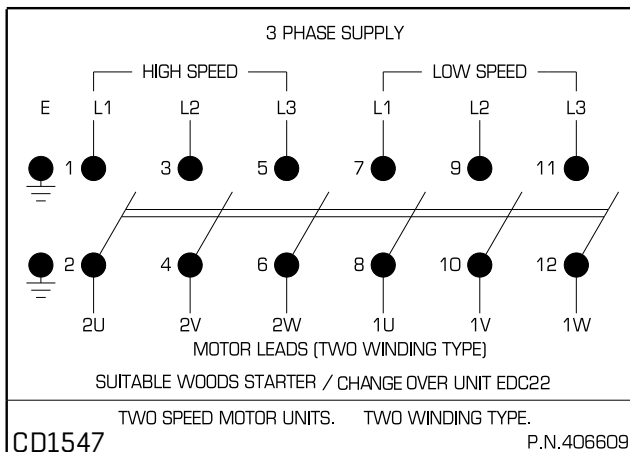
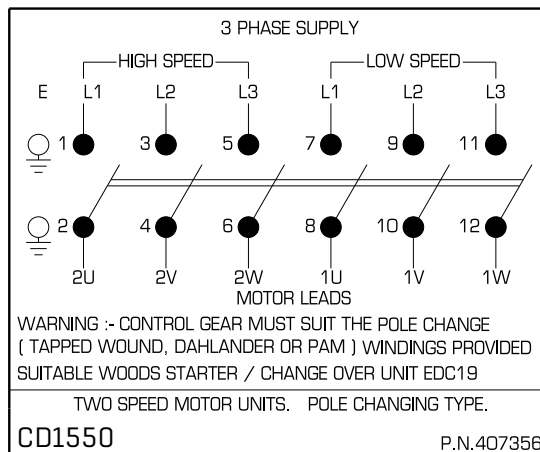
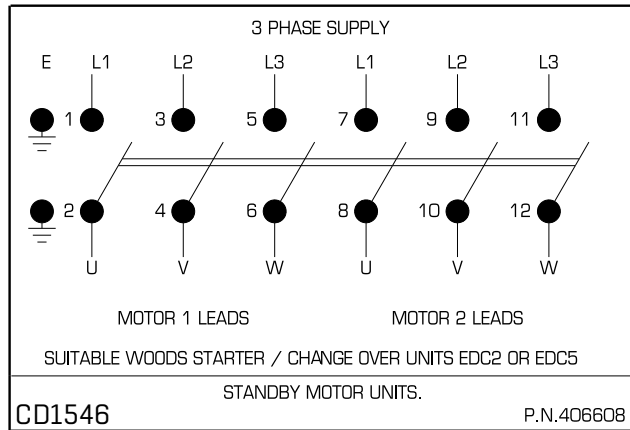
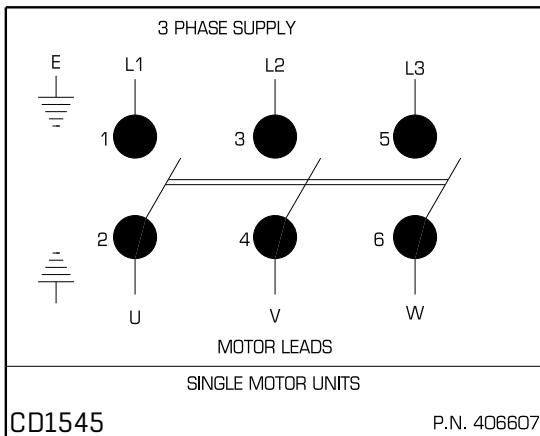

WIRING DETAIL: THREE-PHASE MOTOR, WITH ISOLATOR FITTED

FIGURE 10

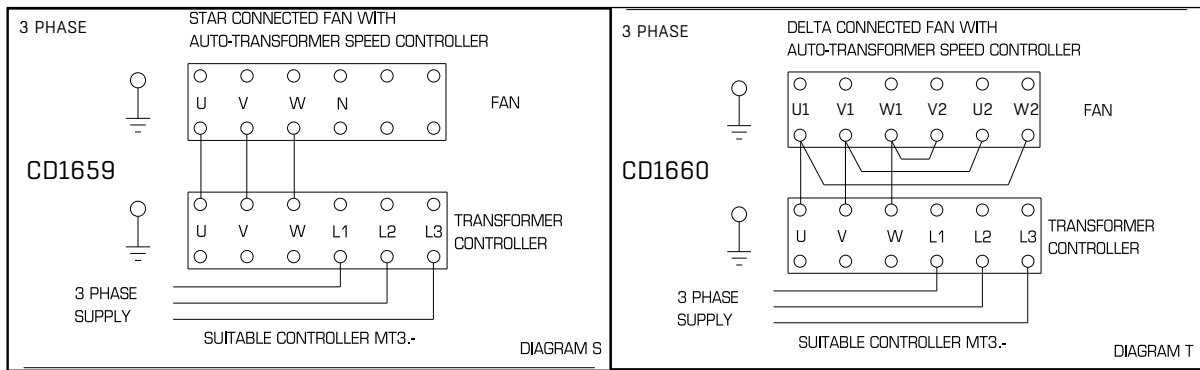

WIRING DETAIL: THREE-PHASE DIRECT-DRIVE MOTOR WITH TRANSFORMER TYPE SPEED CONTROLLER

FIGURE 11

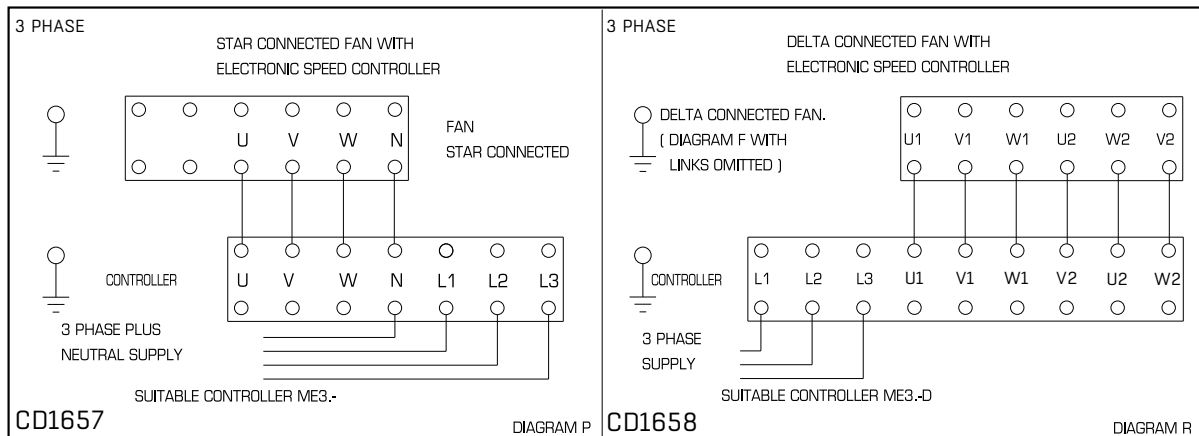

WIRING DETAIL: THREE-PHASE DIRECT-DRIVE MOTOR WITH ELECTRONIC TYPE SPEED CONTROLLER

FIGURE 12

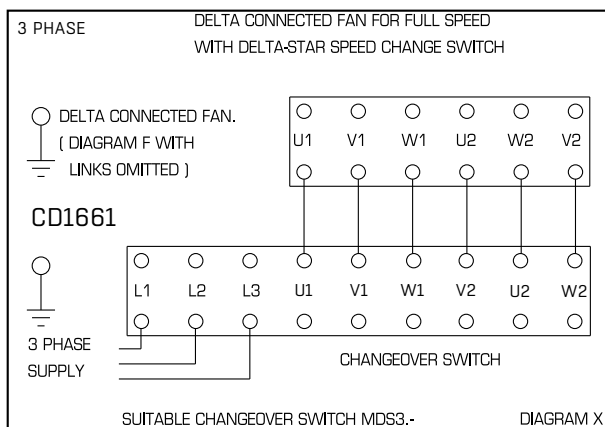

WIRING DETAIL (THREE-PHASE DIRECT-DRIVE MOTOR WITH CHANGEOVER SWITCH)

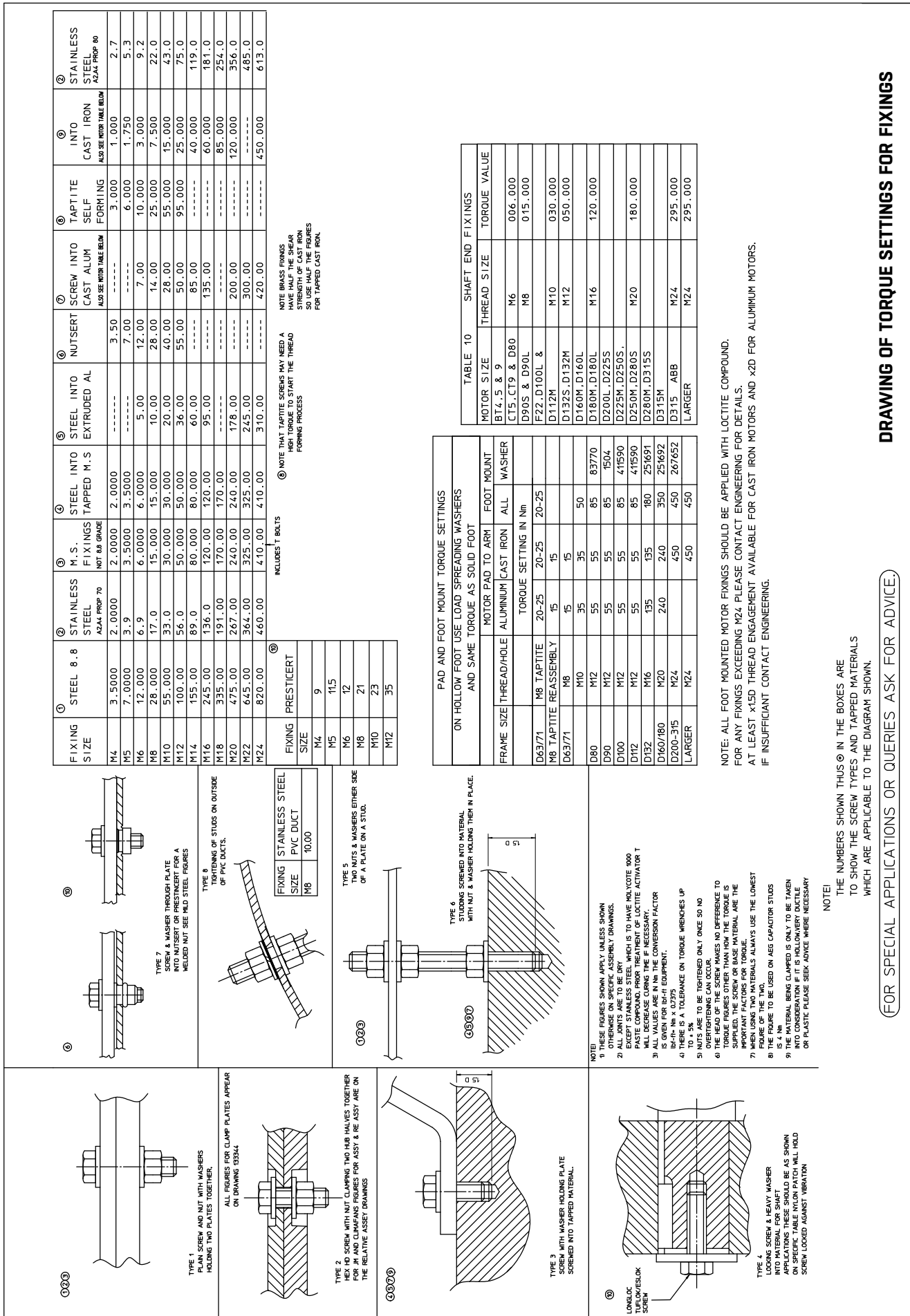

DRAWING OF TORQUE SETTINGS FOR FIXINGS

WE BRING **BETTER AIR**[™] TO LIFE

With over a century of innovation and expertise to share with our customers, Fläkt Woods is a global leader in Air Technology products and solutions. We specialize in the design and manufacturing of a wide range of products and solutions for Air Movement, Air Treatment, Air Distribution, Air Management and Air Diffusion with focus on two major benefits – **Air Comfort** and **Fire Safety**. With market presence in 65 countries we are in a unique position to be a local supplier and an international partner in our customer's projects.

Our product brands such as SEMCO[®], eQ[®], eQ Prime[®], JM Aerofoil[®], Econet[®], Veloduct[®], Optivent[®], Optimix[®], Econovent[®] and Cleanvent[®] are well-known and trusted by customers all over the world to deliver high quality and energy efficient solutions.

WWW.FLAKTWOODS.COM

Fläkt Woods Limited, Axial Way, Colchester, Essex, CO4 5ZD
tel: 01206 222 555
website: www.flaktwoods.co.uk

» See global website for international sales offices www.flaktwoods.com